

# Crown OPTO HP



## ITEM DESCRIPTION

A chain-type module and easy light source design that's compatible with any lighting fixture as a LED light engine. Designed with a special light distribution feature, this is an ideal option for achieving uniform illumination, as well as a perfect lighting solution for stretch ceilings, extra large and deep light boxes and other backlighting applications where high light output and reliability are required. Crown OPTO HP modules come with 5 year warranty with L70 for 60,000 hours.

## APPLICATION

- Ideal for stretch ceiling
- Suitable for extra large and deep light boxes and other backlighting applications

## FEATURES & BENEFITS

- Compact design (48x48mm)
- Wide 170° beam angle
- Efficiency up to 101 lm/W
- Unique cooling system
- IP67 protection class
- 5 year warranty

## GENERAL SPECIFICATIONS

SUPPLY VOLTAGE	24 VDC
POWER	5.0 W
RECOMMENDED DEPTH	160 - 300 mm
TYP. LUMEN OUTPUT	505 lm
CC DISTANCE	600 mm
BINNING	3 SDCM
OPERATING TEMPERATURE	-20°C ~ +50°C
STORAGE CONDITIONS	Relative humidity <60%
IP CLASS	IP 67
LIFETIME	L70 60,000 h
WARRANTY	5 years*

\*Warranty is applied only and if storage, mounting and maintenance conditions, stated in the installation guide, are followed.

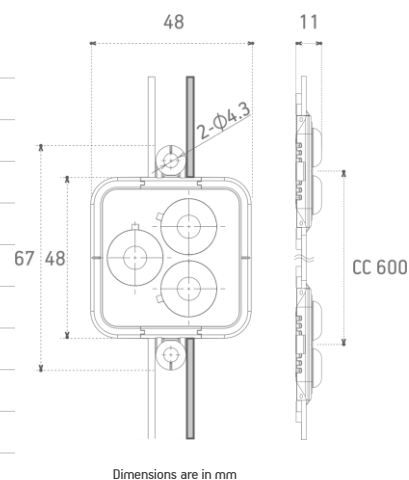

## LIGHT DISTRIBUTION GRAPH

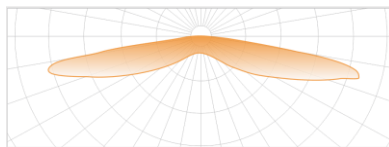

Beam angle: 170°

## ORDERING INFORMATION

PRODUCT NAME	POWER, W	LUMEN OUTPUT, LM	COLOUR	STATUS	SAMPLES
BMP-L3A160865E5-24V	5.0	505	6500 K	PRE-ORDER*	YES
BMP-L3A160850E5-24V	5.0	505	5000 K	PRE-ORDER*	ON REQUEST
BMP-L3A160840E5-24V	5.0	505	4000 K	PRE-ORDER*	YES
BMP-L3A160830E5-24V	5.0	450	3000 K	PRE-ORDER*	YES
BMP-L3A160827E5-24V	5.0	450	2700 K	PRE-ORDER*	ON REQUEST

\* For MOQ and lead time of pre-order products, contact your Customer Service manager.

## QUANTITY

CHAIN	BOX
10 pcs (net weight: 0.400 kg)	320 pcs (net weight: 11.600 kg)