

# CROWN DUO R13V12



## ITEM DESCRIPTION

Crown DUO R13V12 modules are best for double sided light boxes. Equipped with elliptical lenses these modules are designed for depths ranging from 140 to 250 mm, can be installed with 60 – 200 mm step. Crown DUO R13V12 show extreme endurance at harsh working conditions (IP66) and have 3 year warranty with L70 for 25,000 hours.

## APPLICATION

- Double sided light boxes with depth over 120 mm
- Maximum height of light box 1 500 mm
- Bus shelters, city lights

## FEATURES & BENEFITS

- Integrated CC control (11-16VDC)
- IP66 protection class
- CRI >82
- 3 year warranty
- 12 V solution

## GENERAL SPECIFICATIONS

SUPPLY VOLTAGE	12 VDC
POWER	1.45 W
RECOMMENDED DEPTH	From 140 to 250 mm
CC DISTANCE	200 mm
BINNING	3 SDCM
OPERATING TEMPERATURE	-35 °C ~ +50 °C
STORAGE TEMPERATURE	+5 °C ~ +90 °C
STORAGE CONDITIONS	Relative humidity <60%
CERTIFICATION	CE and RoHS compliant
IP CLASS	IP 66
LIFETIME	L70 25,000 h
WARRANTY	3 years*

\*Warranty is applied only and if storage, mounting and maintenance conditions, stated in the installation guide, are followed.

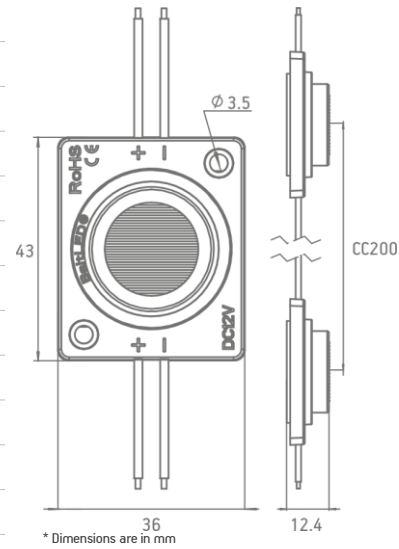

## LIGHT DISTRIBUTION GRAPH

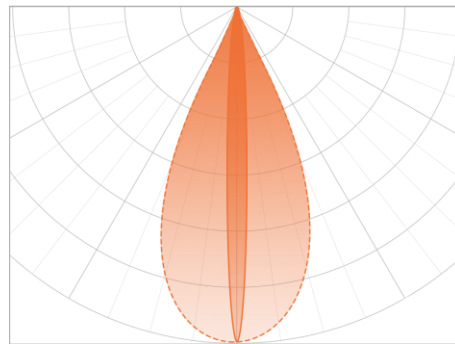

Beam angle: 12x56°

## ORDERING INFORMATION

PRODUCT NAME	POWER, W	LUMEN OUTPUT, LM	COLOUR TEMP.	STATUS
BMS-R13V12-01USELPCW	1.45	110	6500 K	IN STOCK

CHAIN	BAG	BOX
30 pcs (net weight: 0.510 kg)	60 pcs (net weight: 1.020 kg)	90 pcs (net weight: 10.600 kg)