

CROWN DUO R13V12



ITEM DESCRIPTION

Crown DUO R13V12 modules are best for double sided light boxes. Equipped with elliptical lenses these modules are designed for depths ranging from 140 to 250 mm, can be installed with 60 – 200 mm step. Crown DUO R13V12 show extreme endurance at harsh working conditions (IP66) and have 3 year warranty with L70 for 25,000 hours.

APPLICATION

- Double sided light boxes with depth over 120 mm
- Maximum height of light box 1 500 mm
- Bus shelters, city lights

FEATURES & BENEFITS

- Integrated CC control (11-16VDC)
- IP66 protection class
- CRI >82
- 3 year warranty
- 12 V solution

GENERAL SPECIFICATIONS

| | |
|-----------------------|------------------------|
| SUPPLY VOLTAGE | 12 VDC |
| POWER | 1.45 W |
| RECOMMENDED DEPTH | From 140 to 250 mm |
| CC DISTANCE | 200 mm |
| BINNING | 3 SDCM |
| OPERATING TEMPERATURE | -35 °C ~ +50 °C |
| STORAGE TEMPERATURE | +5 °C ~ +90 °C |
| STORAGE CONDITIONS | Relative humidity <60% |
| CERTIFICATION | CE and RoHS compliant |
| IP CLASS | IP 66 |
| LIFETIME | L70 25,000 h |
| WARRANTY | 3 years* |

*Warranty is applied only and if storage, mounting and maintenance conditions, stated in the installation guide, are followed.

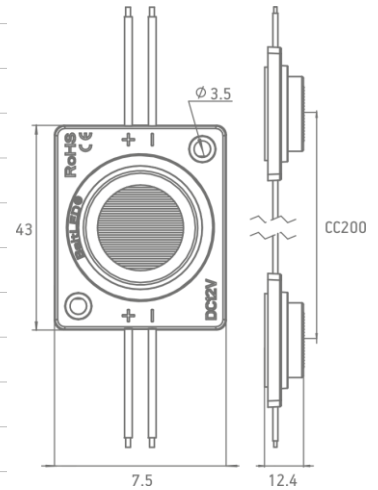

* Dimensions are in mm

LIGHT DISTRIBUTION GRAPH

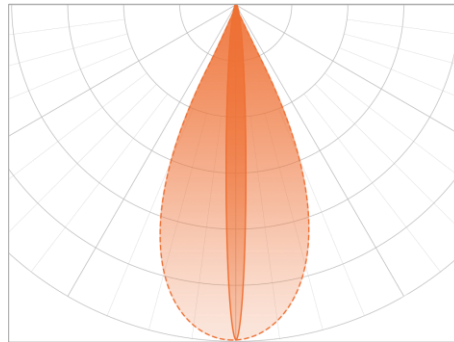

Beam angle: 12x56°

ORDERING INFORMATION

| PRODUCT NAME | POWER, W | LUMEN OUTPUT, LM | COLOUR TEMP. | STATUS |
|----------------------|----------|------------------|--------------|----------|
| BMS-R13V12-01USELPCW | 1.45 | 110 | 6500 K | IN STOCK |

| CHAIN | BAG | BOX |
|-------------------------------|-------------------------------|--------------------------------|
| 30 pcs (net weight: 0.510 kg) | 60 pcs (net weight: 1.020 kg) | 90 pcs (net weight: 10.600 kg) |