

# CROWN DUO STAR



## ITEM DESCRIPTION

With Crown DUO STAR we enable cost-effective illumination of big depth double-sided light boxes. Carbon fiber plastic housing and patented ventilation system allowed us to make lightweight module with impressive ventilation. Therefore, high-power LED could be installed. Special acrylic elliptical lens grants wide angle uniform light distribution pattern.

## APPLICATION

- High brightness illumination of big depth double-sided light boxes
- Recommended depth 140 – 200 mm

## FEATURES & BENEFITS

- High efficiency over 109 lm/W
- Special acrylic elliptical lens
- Carbon fiber plastic housing
- Patented ventilation system
- LM-80 LED certified
- IP67 protection class
- 5 year warranty



## GENERAL SPECIFICATIONS

SUPPLY VOLTAGE	700 mA
POWER	2.1 W
RECOMMENDED DEPTH	From 140 to 200 mm
CC DISTANCE	220 mm
BINNING	3 SDCM
OPERATING TEMPERATURE	-35 °C ~ +50 °C
STORAGE TEMPERATURE	+5 °C ~ +90 °C
STORAGE CONDITIONS	Relative humidity <60%
CERTIFICATION	CE and RoHS compliant
IP CLASS	IP 67
LIFETIME	L70 60,000 h
WARRANTY	5 years*

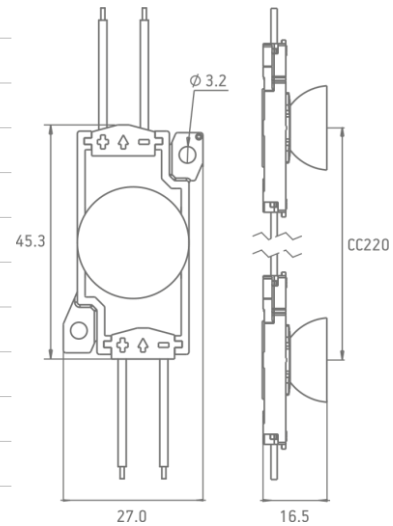

\*Warranty is applied only and if storage, mounting and maintenance conditions, stated in the installation guide, are followed.

\* Dimensions are in mm

## LIGHT DISTRIBUTION GRAPH

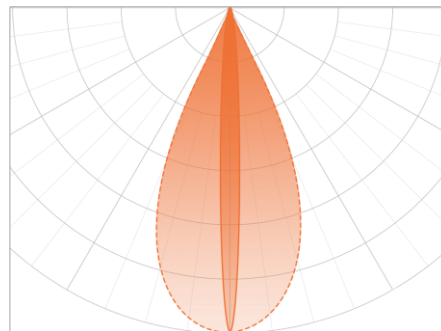

Beam angle: 36° x 16°

## ORDERING INFORMATION

SKU	POWER, W	LUMEN OUTPUT, LM	COLOUR TEMP.	STATUS
BMP-S52.3-01EX0ELW1	2.1	230	6600 K	IN STOCK

CHAIN		BAG		BOX	
15 pcs	(net weight: 0.193 kg)	30 pcs	(net weight: 0.689 kg)	300 pcs	(net weight: 7.900 kg)