

# CROWN DUO R13V12

Crown DUO R13V12 modules are best for double sided light boxes. Equipped with elliptical lenses these modules are designed for depths ranging from 140 to 250 mm, can be installed with 60 – 200 mm step. Crown DUO R13V12 show extreme endurance at harsh working conditions (IP66) and have 3 year warranty with L70 for 25,000 hours.

## Application

- Double sided light boxes with depth over 120 mm
- Maximum height of light box 1 500 mm
- Bus shelters, city lights

## Features & benefits

- Integrated CC control (11-16VDC)
- IP66 protection class
- CRI >82
- 3 year warranty
- 12 V solution

## Technical information

### General specifications

<b>Supply voltage</b>	12 VDC
<b>Power</b>	1.45 W
<b>CCT</b>	6500 ± 250 K
<b>CC distance</b>	200 mm
<b>Recommended depth</b>	From 140 to 250 mm
<b>Operating temp.</b>	-30 °C ~ +50 °C
<b>Storage temp.</b>	-8 °C ~ +60 °C
<b>Certification</b>	CE and RoHS compliant
<b>IP class</b>	IP66
<b>Lifetime</b>	L70 25,000 h
<b>Warranty</b>	3 years*

\* Warranty is applied only and if storage, mounting and maintenance conditions, stated in the installation guide, are followed.

### Light distribution graph

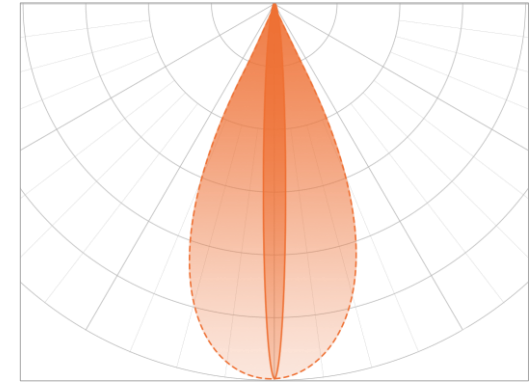

Beam angle: 12x56°

### Dimensions

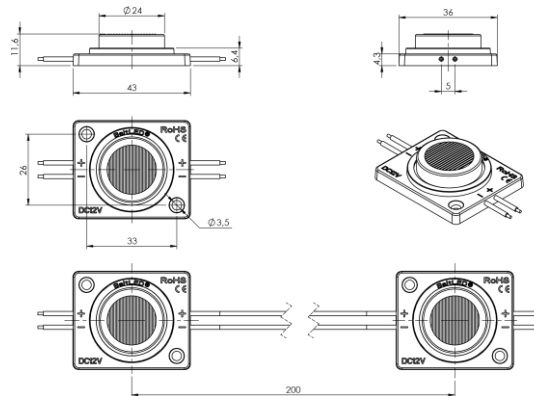

### Ordering information

SKU	Lumens, lm	Colour temp.	Power, W
BMS-R13V12-O1USELPCW	105 – 110	6500 ± 250 K	1.45

#### Ordering quantity

Chain: 30 pcs	(net weight: 0.51 kg)
Bag: 60 pcs	(net weight: 1.02 kg)